

RatioLine R300

Turning/Milling Center



A new dimension in milling and turning

With the R series, INDEX is setting the standard for a new generation of turning/milling centers. Two motorized milling

spindles perform machining in two independent sub-systems, including 5-axis machining. Both heavy-duty roughing operations and highly accurate fine-turning operations can be performed simultaneously on the main spindle and counter

spindle. This parallel use increases productivity significantly compared to conventional designs. New design solutions for optimum stiffness, thermal and dynamic

stability, and vibration damping also provide for maximum machining quality.



Two milling spindles are used simultaneously and independently



Complete machining

- Separate subsystems for upper and lower motorized milling spindles, allowing full rear end machining or parallel machining
- Simultaneous 5-axis machining on both spindles possible
- Generous tool memory for high flexibility
- Tool strips with a total of 12 stationary tools permanently in the working area

Speed

- Parallel machining with 2 milling spindles
- High accelerations and rapid traverse rates
- Typical chip-to-chip time of only 6 seconds for automatic tool changing
- Short traversing distances in a very easy-to-access and easy-to-view working area
- Powerful motorized milling spindles for high cutting efficiency

Solid construction with impressive kinematics

Due to intelligent kinematics with an efficient arrangement of axes, a trend-setting machine concept has emerged that also facilitates comprehensive complete machining operations.

The idea: A vertical machine arrangement in which the main spindle moves in the Z direction, the counter spindle in the X and Z directions, tool carrier 1 in the X, Y, and B directions, and tool carrier 2 in the Y and B directions.

The result: A design with two independent sub-systems, exceptional stiffness between moving components and machine bed, as well as impressive dynamic response. Consequently, the workpieces to be machined can be produced highly efficiently and simultaneously on the front and reverse sides.

The machine further offers several extras: Up to 140 tool stations are optionally available via a double-chain magazine. In the process, a separate loading unit also facilitates machine tooling during the main time.

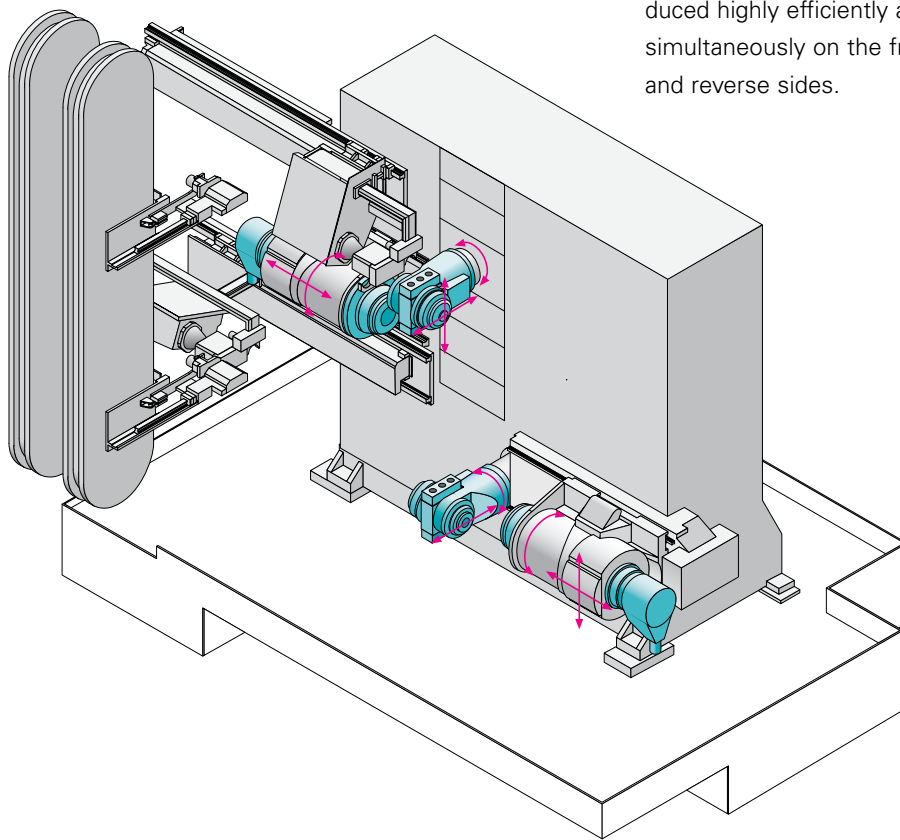

Setup during main time with the tool loading unit

- 8 setup tool mountings
- A cross-slide unit in the magazine feeds and discharges the setup tools.

Work spindles

Two identically-rated motorized spindles designed in synchronous technology and with liquid cooling provide for high cutting volumes.

Motorized milling spindles

The two motorized milling spindles are also designed in synchronous technology with fluid cooling. High rotational speeds and minimum ramp-up times stand for high-performance machining.

Tool strips

Two holding strips affixed to the side of each milling spindle allow fast access to stationary tools with high precision. The W-type serration minimizes the setup effort for these tools.

Workpiece removal

An integrated gantry-type removal unit enables fast handling of workpieces without damage. Finished parts are placed on a conveyor belt and bar remnants in a separate remnant container.

- \varnothing 102 mm
- 3,500 rpm
- 52 kW, 690 Nm (at 40 %)
- Rapid traverse rate 40 m/min

- 24.5 kW, 9,000 rpm
- Tool carrier, upper X/Y 580/280 mm, B 270°
- Tool carrier, lower: Y 280 mm, B 270°
- Rapid traverse 40/30 m/min

- 6 stationary tools on each milling spindle
- Maximum precision for turning operations

- Workpiece/remnant removal possible for main spindle and counter spindle
- Rapid traverse rate 60 m/min



Circular guide: From the center of the machine bed

INDEX

Circular guide

- High stiffness
- Transmission of force via short lever arms
- High dynamic response
- Best damping and guiding properties

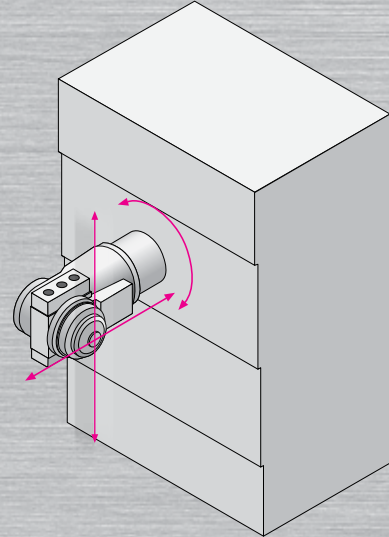

During development of the R series, emphasis was placed on achieving a high degree of stiffness, thermal and dynamic stability, and vibration damping. For this reason, a vertical cast machine bed with a heavily ribbed, en-closed modular design

was chosen. The motorized milling spindles are placed in the center of the machine and are operated freely and wear-free in the Y- and B-axes via hydrostatic circular guides. The guide system contributes considerably to the machine's enormous

stiffness. Optimum force transmission is another premise that was implemented consistently. The short lever arms help to keep the system very stable; vibrations are reduced, and the radial run-out is improved. Another benefit includes the

high accelerations and rapid traverse rates at which the R300 can be operated. These are made possible through the use of weight-optimized assemblies and through purposefully designed drives.

Benefits resulting from the enclosed modular concept and hydrostatic circular guide in the INDEX design

- Better workpiece quality
- Extended tool service life
- Higher rapid traverse rates and accelerations
- Increased machining performance

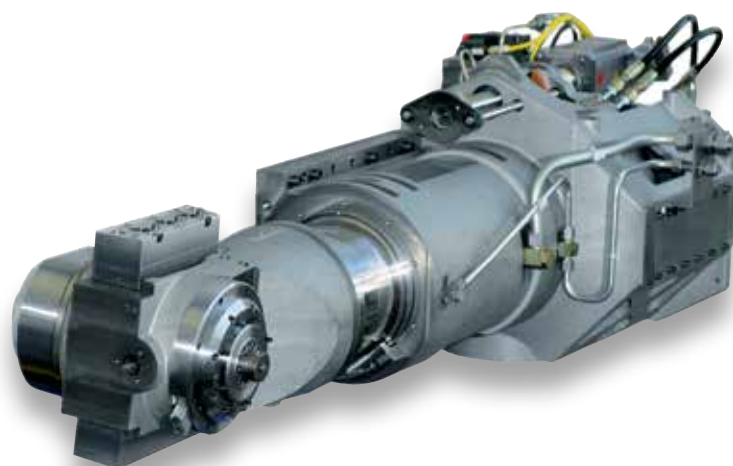



The magazine – all tools on board

Two separate shuttle units independently supply the two motorized milling spindles with the tools required in each case from the tool magazine. With a maximum of 140 tool pockets, the R300 has a large tool set. Chip-to-chip time of 6 seconds contributes to minimizing secondary processing times.

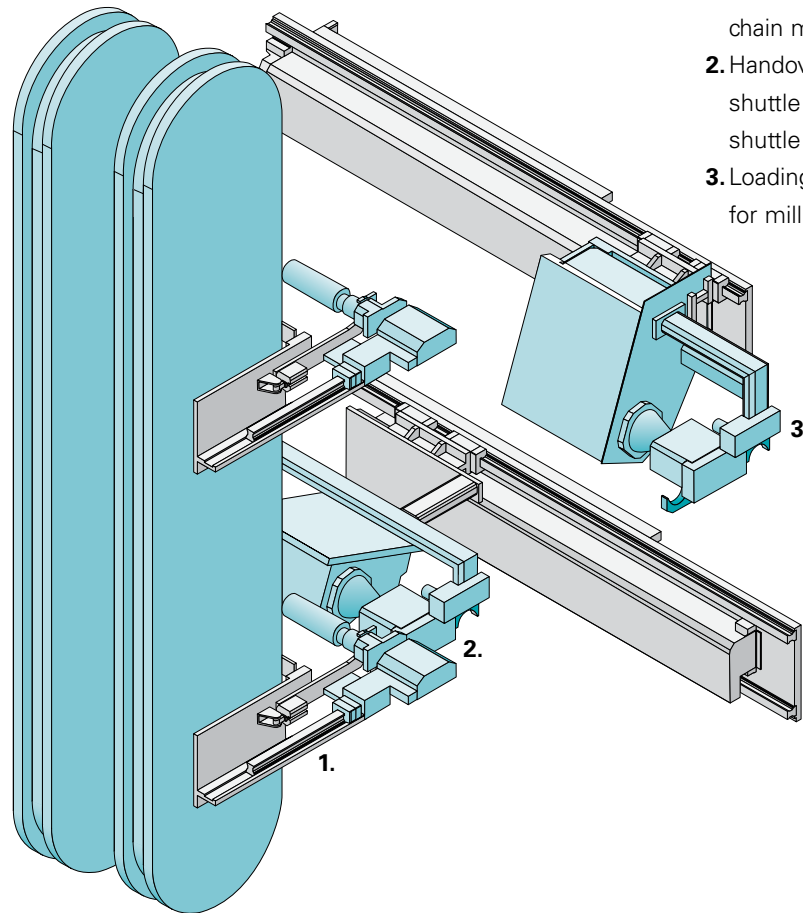

1. Transverse shuttle for removal of tools from chain magazine
2. Handover from transverse shuttle to longitudinal shuttle via double gripper
3. Loading position of tool for milling spindle

At a glance

- 70/140 tool stations (HSK-T63 holder)
- Minimum load cycles; Chip-to-chip time only 6 s
- Simultaneous and independent changes at both milling spindles possible
- High degree of functional reliability due to standard tool magazine with chain design

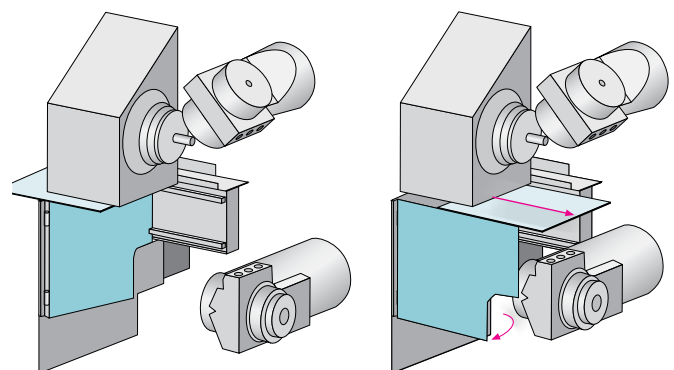

Reducing secondary processing time:

While machining is performed on the main spindle, the lower spindle can load a new tool

(and in reverse), protected from falling chips and coolant. This results in higher productivity and improves process reliability.



Efficient use of energy

For years, INDEX has viewed the efficient use of energy and resources as a key requirement in its machine development activities. Therefore, today all machines already conform to the principle of reduced energy consumption with simultaneous improvement in environmental compatibility. Design experience, such as measurements on machines in the field, form the basis for meeting or even surpassing requirements regarding energy/resource efficiency sustainably, also in the future.

Weight reduction:

- **Reduction of energy consumption**

Simulation programs enable minimization of weights of moving assemblies, while simultaneously optimizing stiffness and damping of machines. Assemblies with reduced weights consume significantly less energy during braking and acceleration.

- **Increased dynamic response**

Standard available motor designs and frame sizes are sufficient for achieving above-average high acceleration, braking, and rapid traverse rates at reduced weights. Smaller motors consume less energy and also exhibit less energy losses.

Energy recovery/energy shutdown:

- **Energy recovery**

Regenerative drives in the turning/milling center transform the motion energy from all braking operations on spindles and axis drives directly into electrical energy and feed it back to the supply network. This reduces energy consumption on a sustainable basis and reduces the heat emission in the proximity of the machine.

- **Energy shutdown**

The R series has an automated shut-down function that shuts down all high-consumption units in case of an unscheduled interruption in production according to a freely selectable time (standby mode).

Minimized friction:

- **Optimum material pairings**

Optimized material pairings and surface coatings reduce the coefficient of friction and, thus, the energy consumption of moving components.

- **Low-friction bearings**

The hydrostatic bearings used on the tool carrier quills are practically free of friction. This minimizes friction heat and energy losses; in addition, these bearings are practically wear-free.

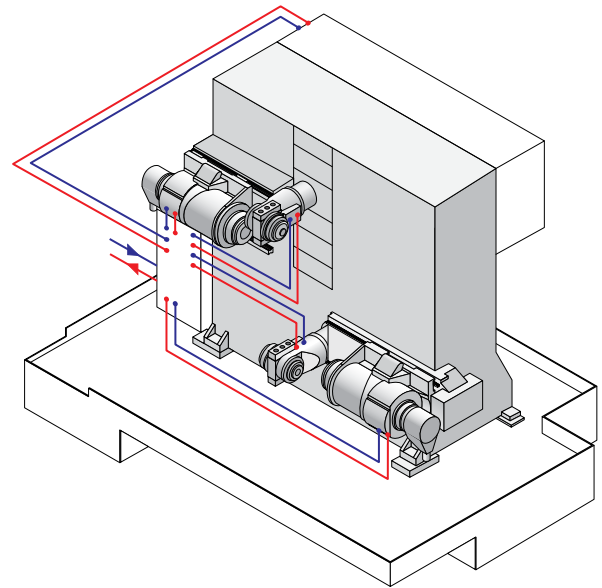

Intelligent use of proven

cooling principles:

- **Targeted heat dissipation**

All high-loss heat sources of the R series are cooled directly via several fluid circuits using different coolants. In addition to main, counter, and milling spindles, the hydraulics and the control cabinet have a separate cooling circuit. The heat energy released is directly connected to the fluid and routed centrally out of the machine.

- **Economic use of waste heat**

The INDEX "cold water interface" allows the heat loss energy stored in the coolant to be removed from a central location and conveyed for another use, if required, e.g., production hall heating, industrial water heating or processing heat for other production steps. The recovery of machine

waste heat facilitates a sustained reduction in energy costs in the company.

- **Climate-neutral dissipation of heat**

The cold water interface provides the ability to dissipate heat in a climate-neutral manner, if the machine waste heat stored in the cooling medium cannot be used in otherwise. The necessary cooling unit can be used with the help of the water interface first on the outside of the production hall and secondly also centrally for several machines. This offers a considerable energy savings potential for production hall heating dissipation/climate control or increased efficiency as a result of centralized heat disposal.



A control designed according to user's wishes

Reliable handling

The INDEX C200-4D SL control is based on the field-proven SIEMENS SINUMERIK S840D Solution Line, paired with drives from the

SIEMENS SINAMICS series. INDEX enhanced this field-proven C200-4D SL control with additional user-friendly functions. These specially designed machine and

machining cycles make even the most complex machining operations available with ease. They support high-efficiency multi-axis milling and turning operations and provide

maximum functional reliability. The result is a control that is designed to meet the machine operator's needs.

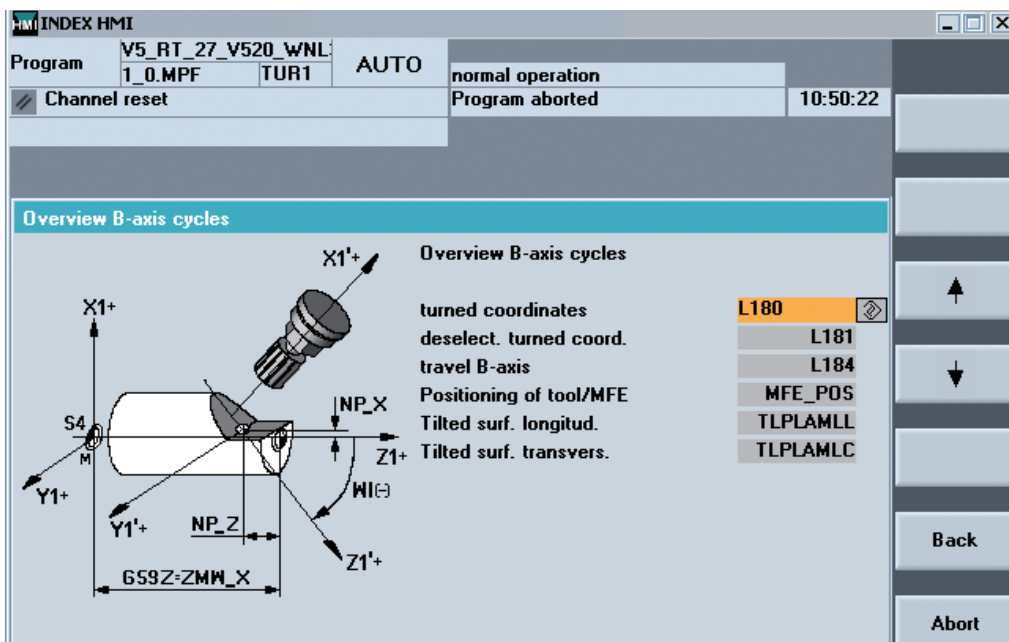

Simple tool selection

The programmer decides which new tool is to be provided and when – separately and independently for both tool carriers. Simultaneous tool change is also possible. The tool pool in the magazine can be used by both tool carriers without restriction.



Easy to program

A large number of powerful user cycles ensure:

- Simple and fast programming
- Field-oriented applications
- Tested and reliable operation of functions
- Maximum flexibility
- Short machining times and optimum machine utilization

Optimum support

The software products of the INDEX VirtualLine, such as the CNC Programming Studio, provide optimum support for programming and operation.

Superior optimization

In conjunction with the process simulation of the the Virtual Machine, machining programs can be created, checked, and optimized on the computer.

Economical production

Numerous additional control functions support user requirements during manufacturing and, thus, provide for efficient and economical production:

- Direct access to wear offsets
- Adapter transformation for all tool stations
- Start requirements for initial state before a restart
- Plain-text error display

- Online access to diagnostics manual via the control
- Multi-channel block search for interruption or destination block
- Tool break monitoring (option)



SINUMERIK

KAN1 AUTO
Normalbetrieb
Programm abgebrochen 19:21:07

Spindelposition

Ablauftyp Typ 0
Betriebsart Nur B Achse
Bearbeitung mit Frässpindel
Position B 90.0000

Spindelposition SPOS 0.0000
Verriegeln / Klemmen LH mit Leserhalt



zurück

Abbruch

OK

Alphanumeric keypad with letters A-Z and numbers 0-9.

Function keys including arrow keys, a home key, and a yellow warning key.

CTR CLR SEL

Emergency stop button (red) and a power button.

INDEX C200-4D control panel with rotary dials for speed and feed rate, and a grid of directional keys.

Emergency stop button (red) with a yellow base.

INDEX C200-4D

White keyboard connected to the control panel.

RatioLine R300

Working area

Dimensions

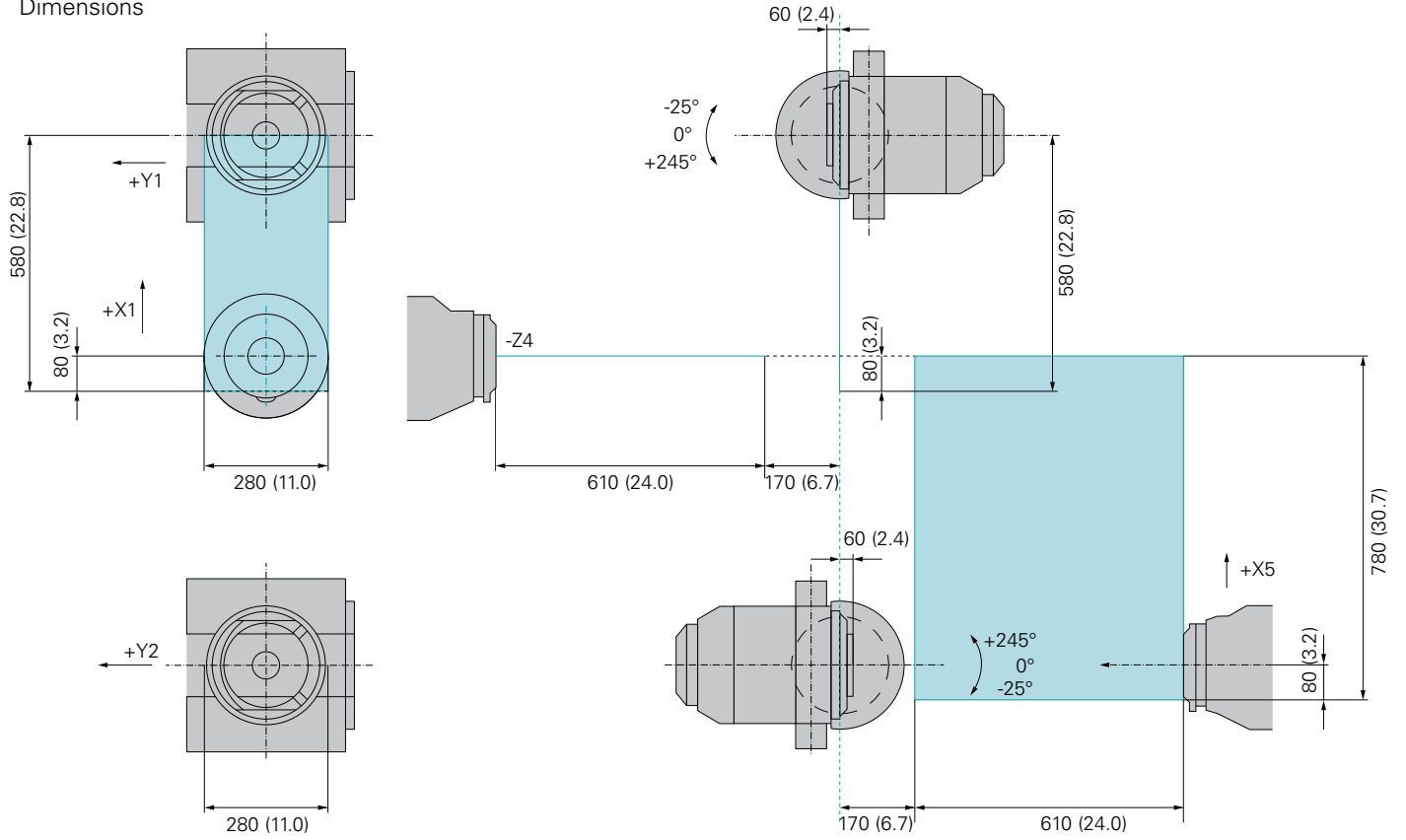

R300 with short bar loader

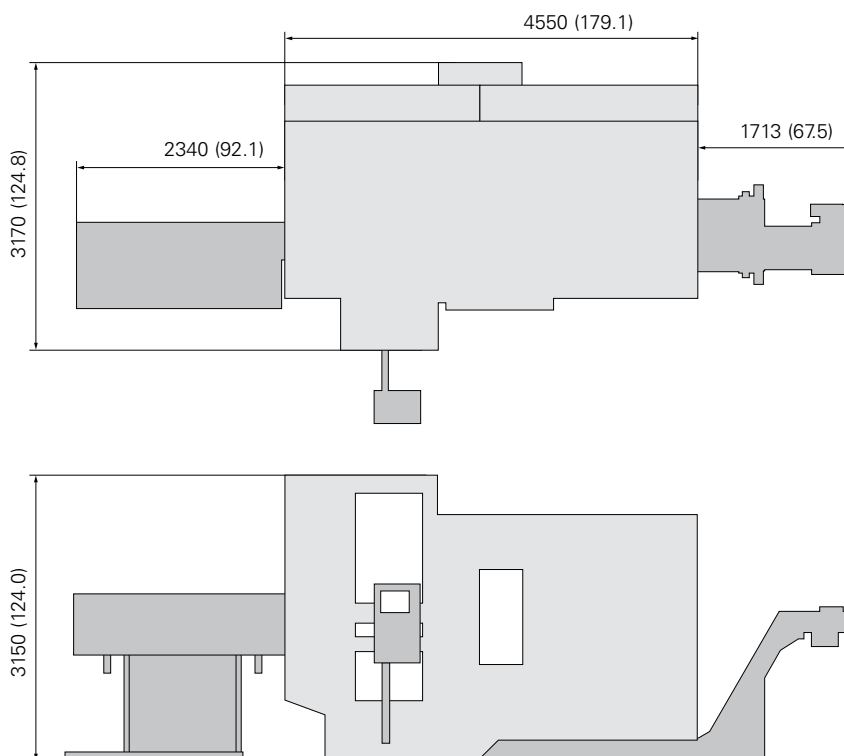

Technical data

Main spindle, counter spindle	Unit	Value
Bar capacity	mm (inch)	102 (4.01)
Spindle diameter in front bearing	mm (inch)	140 (5.5)
Spindle nose ISO 702/1	Size	8
Chuck diameter	mm (inch)	315 (12.4)
Speed	rpm	3500
Power at 100% / 40%	kW (hp)	47 (63.0) / 52 (84.5)
Torque at 100% / 40%	Nm (ft lbn)	450 (331.9) / 690 (508.9)
C-axis resolution	Degrees	0.001
Feed drive of main spindle		
Minimum distance for collet	mm (inch)	22 (0.9)
Slide travel of Z-axis	mm (inch)	610 (24.0)
Rapid traverse rate	m (inch) / min	40 (1574.8)
Resolution	µm	0.02
Feed force	N	7000
Feed drive of counter spindle		
Minimum distance for collet	mm (inch)	22 (0.9)
Slide travel of Z-axis	mm (inch)	610 (24.0)
Slide travel of X-axis	mm (inch)	780 (30.7)
Rapid traverse rate X, Z	m (inch) / min	40 (1574.8)
Resolution X, Z	µm	0.02
Feed force X, Z	N	7000
Tool carrier 1		
Quill diameter	mm (inch)	240 (9.5)
Slide travel X	mm (inch)	580 (22.8) (80 [3.2] below spindle center)
Slide travel Y	mm (inch)	± 140 (5.5)
B-axis angle of rotation	Degrees	270
Brake holding torque B-axis	Nm (ft lbn)	3000 (2212.7)
Tool carrier 2		
Quill diameter	mm (inch)	240 (9.5)
Slide travel Y	mm (inch)	± 140 (5.5)
B-axis angle of rotation	Degrees	270
Brake holding torque B-axis	Nm (ft lbn)	3000 (2212.7)
Motorized milling spindle		
Tooling system DIN 69893		HSK-T63 (optional PSC-63)
Holding force of clamping assembly	N	approx. 24000
Maximum speed	rpm	9000
Power at 100%	kW (hp)	24.5 (32.9)
Torque at 100% / 25%	Nm (ft lbn)	65 (47.9) / 95 (70.1)
Brake holding torque	Nm (ft lbn)	400 (295.0)
Fixed tool stations on tool strips		6 x VDI30
Tool magazine		
Max. tool length	mm (inch)	300 (11.8)
Max. tool diameter	mm (inch)	70 (2.6y) (160 [6.3] with limitations)
Max. tool weight	kg (hp)	5 (11.1)
Chain spacing	mm (inch)	75 (3.0)
Number of tools		70
Gantry-type removal unit		
Slide travel (Z-axis)	mm (inch)	2090 (82.3)
Rapid traverse rate	m (inch) / min	60 (2362.2)
Max. workpiece diameter / length	mm (inch)	100 (3.9) / 250 (9.9) (320 (12.6) remnant length)
Max. workpiece weight	kg (lbs)	15 (33.1)
Weights and connecting values with max. configuration		
Weight	kg (lbs)	ca. 18500 (40784.8) (excl. approx. 4200 (9259.3) kg periphery)
Connecting values		114 kW, 135 kVA, 194 A, 400 V, 50/60 Hz
Control		INDEX C200-4D (based on Siemens S840D sl)

INDEX

LF9802.4576-04.15 WA Printed in Germany Subject to change without prior notice.

INDEX-Werke GmbH & Co. KG

Hahn & Tessky

Plochinger Straße 92

73730 Esslingen, Germany

Phone +49 (711) 3191-0

Fax +49 (711) 3191-587

www.index-werke.de